

EH-S270IBKT

Features/产品特性

- 外观尺寸/ Package (L/W/H) : 1.75*0.6*1.1 mm
- 颜色/ Color: 冰蓝光 / Ice blue light
- 胶体/ Lens: 黄色平面胶体/ Yellow planar colloid
- EIA 规范标准包装/ EIA STD Package
- 环保产品, 符合 ROHS 要求/ Meet ROHS, Green Product
- 适用于自动贴片机/ Compatible With SMT Automatic Equipment
- 适用于红外线回流焊制程/ Compatible With Infrared Reflow Solder Process

Applications/产品应用

- 仪表板和开关中的背光/Backlighting in dashboard and switch.
- 电信: 电话和传真中的指示灯和背光/Telecommunication: indicator and backlighting in telephone and fax.
- LCD 平板背光/Flat backlight for LCD
- 一般用途/General use.

Device Selection Guide/选择指南

Chip Materials	Emitted Color	Resin Color	Manufacturer
AlGaInp	Ice Blue	Yellow	EHAOAN

Package Dimensions/尺寸参数

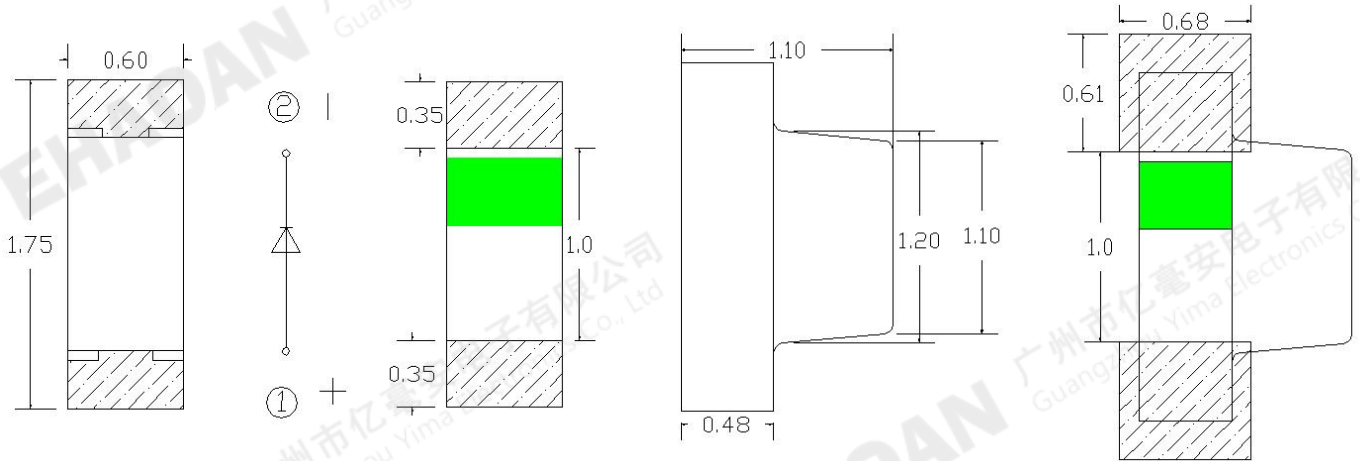

Note: Tolerances unless mentioned ± 0.1 mm. Unit = mm
注：除非另有说明，否则公差为 ± 0.1 mm 单位=mm

Absolute Maximum Ratings / 最大限度参数值(Ta=25°C)

参数名称 Parameter	符号 Symbol	最大额定值 Rating	单位 Unit
正向电流 Forward Current	I _F	20	mA
峰值电流 Peak Forward Current	I _{FP}	60	mA
反向电压 Reverse Voltage	V _R	5	V
消耗功率 Power Dissipation	P _d	70	mW
工作温度 Operating Temperature	T _{opr}	-40~+85	°C
存储温度 Storage Temperature	T _{stg}	-40~+85	°C
焊接温度 Soldering Temperature	T _{sol}	回流焊: 260°C, 10s 手动焊: 300°C, 3s	

Opto-Electrical Specification / 主要光电参数

参数名称 Parameter	符号 Symbol	最小值 Min	标准值 Type	最大值 Max	单位 Unit	测试条件 Condition
光强 Luminous Intensity	I _v	100	--	210	mcd	I _F =5mA
半光强视角 Viewing Angle	2θ _{1/2}	--	120	--	deg	I _F =20mA
色座标 CIE 1931 Coordinate	X	---	0.18	---		I _F =5mA
	Y	---	0.27	---		
半值波长 Spectral Line Half-Width	Δλ	---	15	---	nm	I _F =5mA
正向电压 Forward Voltage	V _F	2.6	--	3.0	V	I _F =5mA
反向电流 Reverse Current	I _R	--	--	5	uA	V _R =5V
色温 Color Temperature	CCT	100000	--	--	K	I _F = 5mA

Photoelectric parameters are divided into BIN specifications/光电参数分 BIN 规格

Range of Luminous Intensity/亮度分 BIN

Bin	Min	Max	Unit	Condition
P19	100	120	MCD	IF = 5mA
P21	120	145		
P22	145	175		
P23	175	210		

Notes: Tolerance of Luminous Intensity: $\pm 10\%$

Range of Forward Voltage/电压分 BIN

Bin	Min	Max	Unit	Condition
VM	2.6	2.7	V	IF = 5mA
VN	2.7	2.8		
VO	2.8	2.9		
VP	2.9	3.0		

Notes: Tolerance of Forward Voltage: $\pm 0.05V$

Color distinguishes Bin specifications/色区分 BIN 规格

色区代码	X1	Y1	X2	Y2	X3	Y3	X4	Y4	色温(K)
OM1	0.1831	0.2425	0.1731	0.2446	0.1752	0.2546	0.1852	0.2525	100000 以上
OM2	0.1852	0.2525	0.1752	0.2546	0.1773	0.2646	0.1873	0.2624	100000 以上
OM3	0.1873	0.2624	0.1773	0.2646	0.1795	0.2745	0.1894	0.2724	100000 以上
OM4	0.1894	0.2724	0.1795	0.2745	0.1816	0.2845	0.1916	0.2824	100000 以上
OM5	0.1916	0.2824	0.1816	0.2845	0.1837	0.2945	0.1937	0.2924	100000 以上
OM6	0.1937	0.2924	0.1837	0.2945	0.1858	0.3045	0.1958	0.3023	100000 以上

Notes: color coordinate tolerance:±0.005

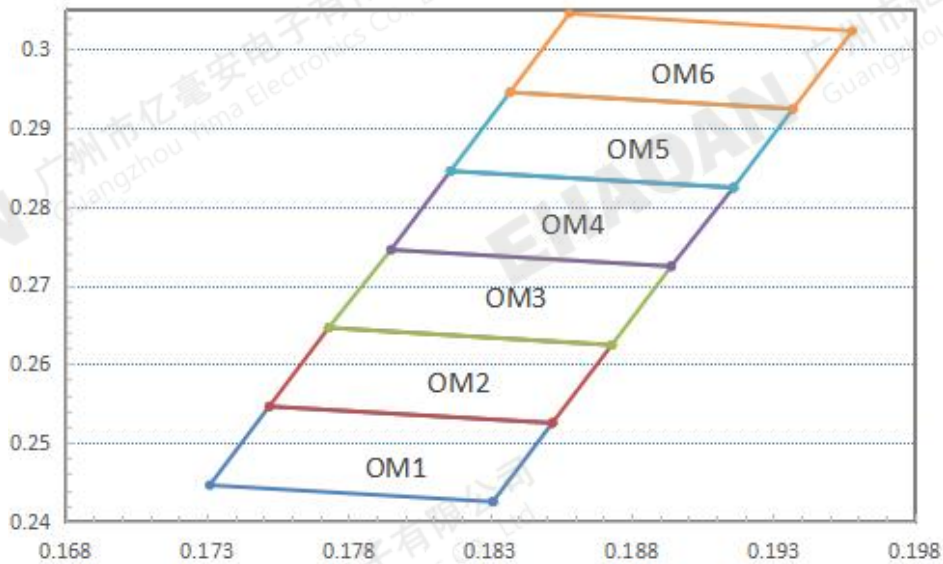

Typical Characteristics Curves/曲线参数

伏安特性曲线

Forward Current VS. Forward Voltage (Ta=25°C)

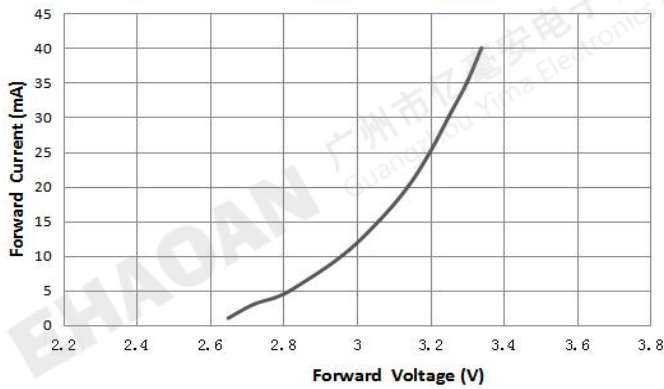

光谱分布特性曲线

Spectrum Distribution (Ta=25°C)

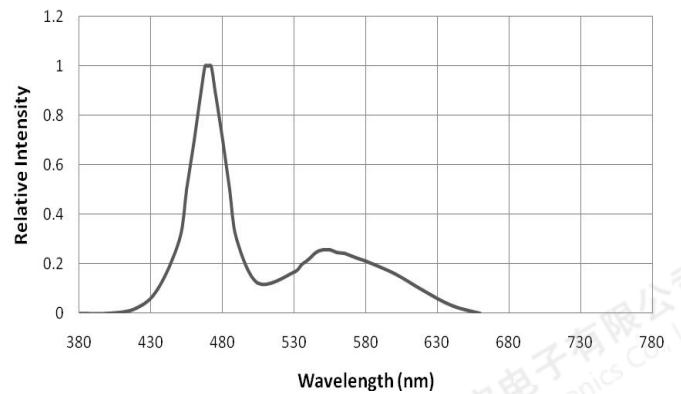

相对光强与环境温度特性曲线

Relative Intensity VS. Ambient Temperature (Ta=25°C)

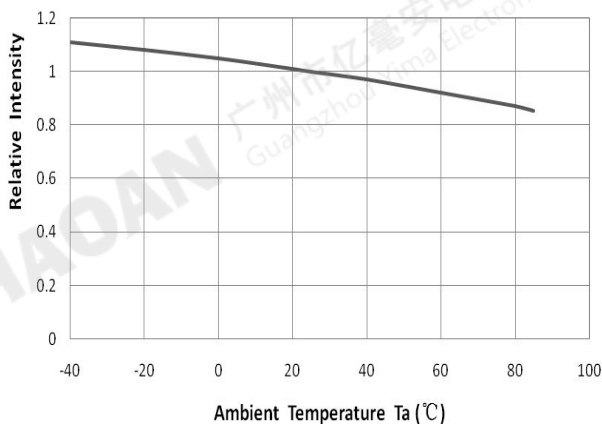

相对光强与电流特性曲线

Relative Intensity VS. Forward Current (Ta=25°C)

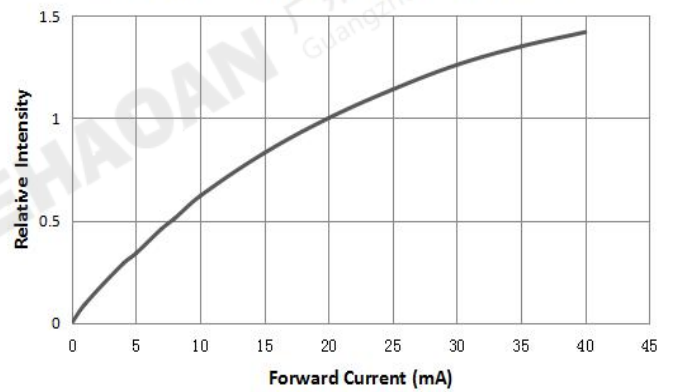

最大正向电流与环境温度特性曲线

Maximum Forward Current VS. Ambient temperature

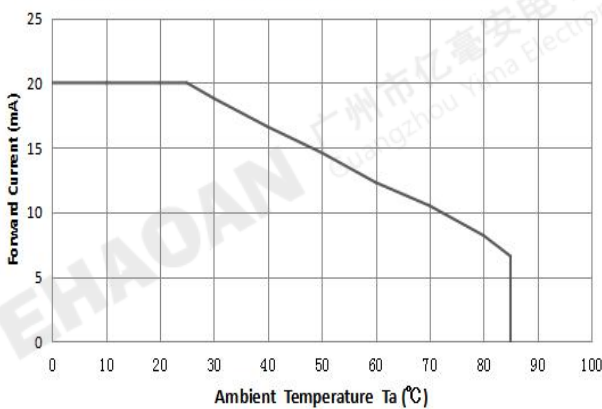

辐射特性曲线

Diagram characteristics of radiation

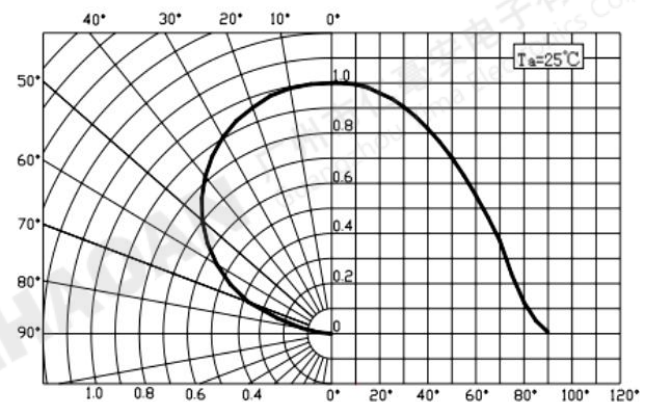

Reliability Test/可靠性试验

测试项目 Test Item	参考标准 Ref.Standard	测试条件 Test Condition	时间 Time	数量 Quantity	接收/拒收 Accepted/Rejected
回流焊 Reflow	JESD22-B106	Temp:255°Cmax T=10 sec	1times	22	0/1
冷热冲击 Thermal Shock	JESD22-A106	-40°C 30min ↑↓ 100°C 30min	100 cycles	22	0/1
高温保存 High Temperature Storage	JESD22-A103	Temp:100°C	168Hrs.	22	0/1
低温保存 Low Temperature Storage	JESD22-A119	Temp:-40°C	168Hrs.	22	0/1
常温通电 Life Test	JESD22-A108	Ta=25°C IF=20mA	168Hrs.	22	0/1
高温高湿 High Temperature / High Humidity	Qiangsq831	85°C/ 85%RH	168Hrs.	22	0/1

Criteria For Judging Damage/失效判定标准

项目 Test Items	符号 Symbol	测试条件 Test Condition	判定标准 Judging For Damage	
			Min	Max
正向电压 Forward Voltage	VF	IF=5mA	-	U.S.L*)x1.1
漏电流 Reverse Current	IR	VR =5V	-	U.S.L*)x2.0
光强 Luminous Intensity	Mcd	IF=5mA	L.S.L*)x0.7	

U.S.L: Upper standard level 规格上限

L.S.L: Lower standard level 规格下限

Moisture Resistant Packing Materials/标签标识



CAT: Ranks
 HUE: Peak Wavelength
 REF: Reference
 QTY: Packing Quantity
 LOT No: Lot Number

Packing/最小包装: 4000 pcs/ reel

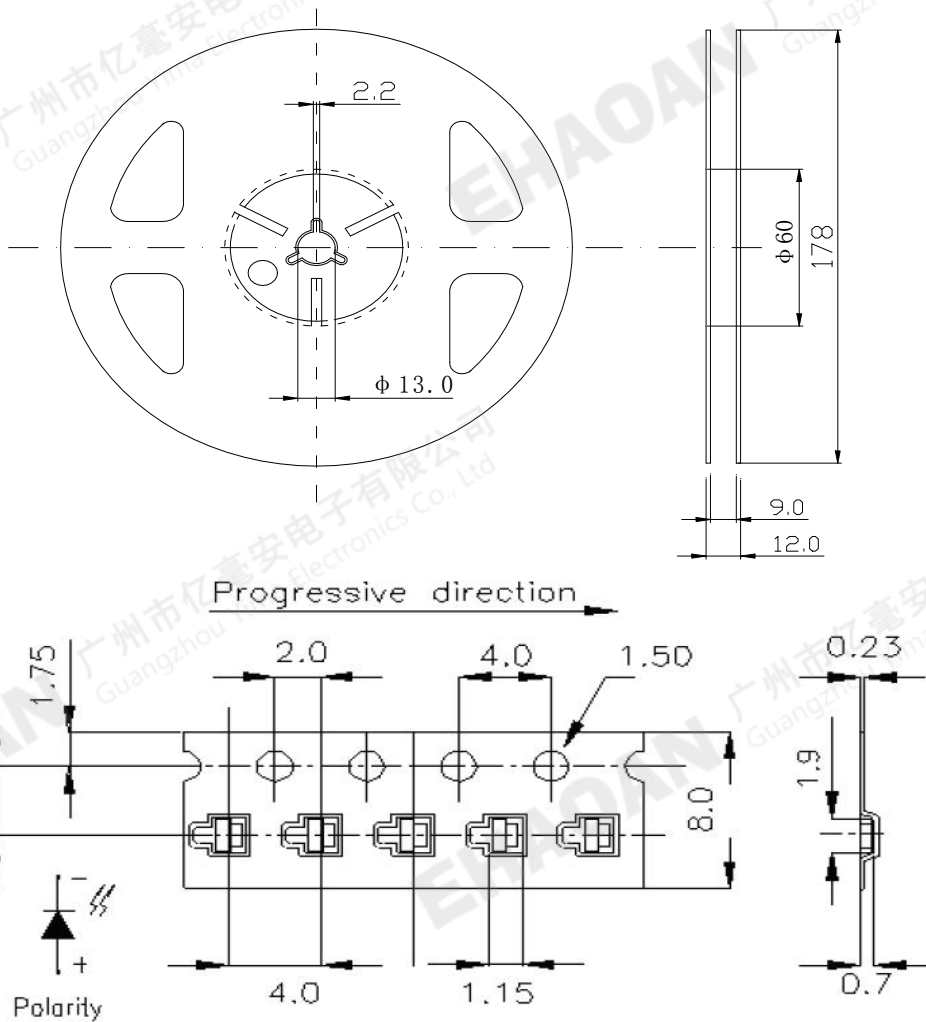

Note: The tolerances unless mentioned is ± 0.1 mm, Unit = mm.
 注: 除非另有说明, 否则公差为 ± 0.1 mm, 单位=mm。

Notes/注意事项

焊接/welding

- 1、SMD LED 灌封胶较软，外力易损坏发光面及塑料壳，焊接时要轻拿轻放。

SMD LED is soft and easy to damage the luminous surface and plastic shell by external force. It should be handled lightly when welding

- 2、建议使用易洗型的助焊剂，依照回流曲线条件回流焊接，回流次数最多两次，确保 LED 发光面干净，异物会影响发光颜色。

It is recommended to use soldering flux with tin wash type, reflow soldering according to the condition of reflux curve, reflow twice at most, ensure the LED luminous surface is clean, foreign matter will affect the luminous color.

- 3、只建议在修理和重工的情况下使用手工焊接；最高焊接温度不应超过 300 度，且须在 3 秒内完成（手工焊接只可焊接一次）烙铁最大功率应不超过 25W

Manual welding is only recommended for repair and heavy industry;The maximum welding temperature should not exceed 300 degrees, and must be completed within 3 seconds (manual welding can only be welded once) soldering iron maximum power should not exceed 25W.

- 4、焊接过程中，严禁在高温情况下碰触胶体；焊接后，禁止对胶体施加外力，禁止弯折 PCB，避免元件受到撞击。

During the soldering process, do not touch the lens at high temperature , After soldering, any mechanical force on the lens or any excessive vibration shall not be accepted to apply, also the circuit board shall not be bent as well.

- 5、请不要将不同 BIN 级的 LED 使用于同一个产品上，否则可能会导致产品的严重色差。

Please do not use different BIN LED on the same product, otherwise it may cause serious color difference.

清洗/cleaning

- 1、不能用超声波清洗,建议使用异丙醇 (isopropyl alcohol)、纯酒精擦拭或浸渍(浸渍不超过 1 分钟)在室温下放置 15 分钟再使用；清洗后,确保 LED 发光面干净,异物会影响发光颜色。

No ultrasonic cleaning. It is recommended to use isopropyl alcohol, pure alcohol to wipe or soak, not more than 1 minute, and leave at room temperature for 15 minutes before use. After cleaning, make sure the LED luminous surface is clean and the foreign matter will affect the luminous color.

- 2、应避免接触或污染天那水,三氯乙烯、丙酮、硫化物、氮化物、酸、碱、盐类,这些物质会损伤 LED.

Avoid touching or contaminating the water, trichloroethylene, acetone, sulfide, nitride, acid, alkali, and salts that can damage leds.

灌封/enbedment

- 1、挥发性物质会渗透到 LED 内部，在通电产生光子及热的条件下，会导致 LED 变色，进而造成严重光衰，严禁使用任何对 LED 器件的性能或者可靠性有害的物质或材料，针对特定的用途和使用环境，建议对所有的物质和材料进行兼容性的测试。在贴装 LED 时候，不要使用能产生有机挥发性气体的粘结剂。

Volatile substances to leach into the LED inside, photons in electricity and heat conditions, will lead to the LED color, thus causing serious droop, it is forbidden to use any of the LED device performance or reliability of harmful substances or materials, for a specific purpose and use of the environment, advice on all the material and the material compatibility test.When attaching LED, do not use adhesive that can produce volatile organic gas.

- 2、使用正常灌封胶时,建议先以少量试验，常温点亮 168 小时，确定没有问题再作业。

It is recommended to light up for 168 hours at room temperature for a small amount of test before using normal filling and sealing glue.

保存/save

1、打开包装前,LED 应存储在温度 30°C或以下,相对湿度在 RH60%以下,一年内使用。

Before opening the package, LED should be stored in a temperature 30 °C or below, under RH60 % relative humidity, used in a year.

2、LED 是湿度敏感元件,为避免元件吸湿,打开包装后,LED 应在温度 30°C或以下,相对湿度在 60%以内,使用时间 7 天。LED 吸潮后,回流焊时可能裂胶,影响发光颜色。对于未使用的散件,请去潮处理 (卷装品 : 烘烤 60°C±5°C/24H ; 散装品 : 烘烤 105°C±5°C/1H) ,然后再用铝箔袋密封后保存或者储存在氮气防潮柜内。

LED is humidity sensitive element, element to avoid moisture absorption, after open the packing, the LED should be in temperature 30 °C or below, within 60% relative humidity, using time 7 days. After moisture absorption, LED may crack when reflow soldering, influence the luminous color. For bulk is not used, please deal with the tide (for package product: bake 60 °C + / - 5 °C / 24 h. For bulk goods: baking 105 °C + 5 °C, 1 hours), and then save after sealed with aluminum foil bag or stored in nitrogen moistureproof enclosure

3、保存环境中避免有酸、碱以及腐蚀气体存在 , 同时避免强烈震动及强磁场作用。

Avoid the presence of acid, alkali and corrosive gas in the preservation environment, and avoid strong vibration and strong magnetic field.

静电/electrostatic

1、静电或峰值浪涌电压会损坏 LED,避免在开灯、关灯时产生瞬时电压。

Static electricity or peak surge voltage will damage the LED, avoiding instantaneous voltage when the lamp is turned on or off.

2、建议使用 LED 时佩戴防静电手腕带,防静电手套,穿防静电鞋,使用的设备、仪器正确接地。LED 损坏后,表现出漏电流明显增加,低电流正向电压变低,低电流点不亮等现象。

It is recommended to wear anti-static wrist bands, anti-static gloves and anti-static shoes when using LED. The equipment and instruments used are properly grounded. After the LED was damaged, the leakage current increased obviously, the forward voltage of low current became lower, and the low current point did not light, etc.

测试/test

1、LED 要在额定电流下驱动,同时电路中需要加限流电阻保护 ; 否则,轻微的电压变化就会引起较大的电流变化,从而破坏 LED。

LED shall be driven at rated current, and shall be protected by current-limiting resistance in the circuit. Otherwise, slight voltage changes will cause large current changes, which will damage the LED.

2、在电路导通或关闭情况下,要避免瞬间浪涌电压的产生,否则 LED 将被烧坏。

When the circuit is on or off, avoid sudden surge voltage. Otherwise, the LED will be burnt out

请参照下图检测 LED:/Please check the LED as shown

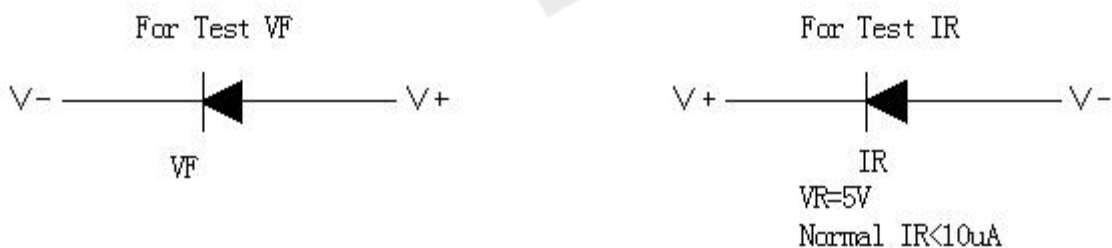

3、顺向电压 V_F 过高或反向电压 V_R 过高，均会损坏 LED。

If the forward voltage V_F is too high or the reverse voltage V_R is too high, the LED will be damaged.

4、点亮或测试 LED 时，加在 LED 两端的反向电压不得高于 5V，否则容易击伤 LED。

When lighting or testing the LED, the reverse voltage added on both ends of the LED shall not be higher than 5V, otherwise it is easy to damage the LED.

5、LED 发光颜色会随着工作电流不同而有少许变化,建议设计时考虑电阻与 LED 串联使用。

LED luminous color will vary slightly with the working current. It is suggested that resistance and LED should be used in series in the design

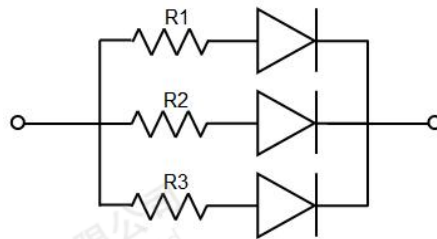

6、LED 容易因为自身的发热和环境的温度改变而改变，温度升高会降低 LED 发光效率，影响发光颜色在设计时应充分考虑散热问题。

LED is easy to change due to its own heat and changes in the temperature of the environment. The increase in temperature will reduce the luminous efficiency of LED, which will affect the luminous color. Heat dissipation should be fully considered in the design